

# The Cost of Mercury Removal in an IGCC Plant

Final Report  
September 2002

*Prepared for:*



The United States Department of Energy  
National Energy Technology Laboratory

*By:*

Parsons Infrastructure and Technology Group Inc.

Reading, Pennsylvania  
Pittsburgh, Pennsylvania

*DOE Product Manager:*  
Gary J. Stiegel

*DOE Task Manager:*  
James R. Longanbach

*Principal Investigators:*  
Michael G. Klett  
Russell C. Maxwell  
Michael D. Rutkowski

## TABLE OF CONTENTS

<u>Section</u>	<u>Title</u>	<u>Page</u>
<b>1</b>	<b>Summary</b>	<b>1</b>
<b>2</b>	<b>Introduction</b>	<b>3</b>
<b>3</b>	<b>Background</b>	<b>4</b>
	3.1 Regulatory Initiatives	4
	3.2 Mercury Removal for Conventional Coal-Fired Plants	4
	3.3 Mercury Removal Experience in Gasification	5
	3.4 Variability of Mercury Content in Coal	6
<b>4</b>	<b>Design Considerations</b>	<b>7</b>
	4.1 Carbon Bed Location	12
	4.2 Mercury Concentration	14
	4.3 Process Parameters	15
	4.4 Mercury Removal	15
	4.5 Carbon Replacement Time	16
<b>5</b>	<b>Design Basis</b>	<b>17</b>
<b>6</b>	<b>Cost Estimate</b>	<b>18</b>
<b>7</b>	<b>Sensitivities</b>	<b>20</b>
<b>8</b>	<b>Applicability of Estimate</b>	<b>22</b>
<b>9</b>	<b>Conclusions</b>	<b>23</b>

## LIST OF TABLES

<u>Table</u>	<u>Title</u>	<u>Page</u>
1	Mercury Content of Coals	6
2	Texaco IGCC Plant – Detailed Composition	9
3	Volumetric Flow Comparison	13
4	Effect of Mercury Removal on Stream Properties	14
5	Design Basis – Mercury Removal by a Carbon Bed – Fixed-Bed Option	17
6	Cost Estimate – Mercury Removal by a Carbon Bed – Fixed-Bed Option	19
7	Sensitivity of Increased Mercury Concentration	20
8	Sensitivity of Key Parameters	20

**LIST OF FIGURES**

<b><u>Figure</u></b>	<b><u>Title</u></b>	<b><u>Page</u></b>
1	Modified Block Flow Diagram – Texaco Gasifier-Based IGCC Reference Plant	8
2	Sensitivity of Key Parameters on Mercury Removal Costs	21

## **LIST OF ACRONYMS AND ABBREVIATIONS**

acf	actual cubic feet
acfm	actual cubic feet per minute
AGR	acid gas removal
CCT	clean coal technology
COS	carbonyl sulfide
EPA	U.S. Environmental Protection Agency
°F	degree Fahrenheit
ft	foot, feet
h	hour
Hg	mercury
IGCC	integrated gasification combined cycle
kW	kilowatt
kWh	kilowatt-hour
lb	pound
lb/ft <sup>3</sup>	pound per cubic foot
MACT	maximum achievable control technologies
MSW	municipal solid waste
MW	megawatt
MWe	megawatts electric
MWh	megawatt-hour
O&M	operations and maintenance
PC	pulverized coal
PE	purchased equipment
ppb	parts per billion
ppbw	parts per billion by weight
psi	pounds per square inch
psia	pounds per square inch absolute
S	sulfur
scf	standard cubic feet
sec	second
TCC	total capital costs

## **1. SUMMARY**

The U.S. Environmental Protection Agency (EPA) has decided to regulate mercury emissions from coal-burning utilities. Mercury has been identified by the EPA as the toxic substance of greatest concern among all the air toxics emitted from power plants. The EPA must propose regulations to control mercury emissions from coal- and oil-fired power plants by December 15, 2003 and issue final regulations by December 15, 2004. Meeting these regulatory requirements without excessive costs is a significant concern. Integrated gasification combined cycle (IGCC) plants offer the capability of removing the mercury from the compressed syngas prior to combustion where the gas volume treated is much less than the low pressure, post-combustion flow volume; thus the process is much less costly. In addition, the technology of removal of mercury in an IGCC plant has already been commercially demonstrated to remove greater than 90 percent of the mercury. This study was to determine the cost of such a removal system as applied to commercial-scale IGCC plants and show that the performance and cost levels are acceptable.

Currently, there is no single proven technology that can uniformly control mercury from power plant flue gas emissions in a cost-effective manner, while consistently achieving mercury removal levels of 90 percent. The effectiveness of existing flue gas emission controls in removing mercury can vary considerably from plant to plant, or even from boiler to boiler. With today's technologies, mercury removal can range from essentially no control to as high as 90 percent. This variability in control costs and performance expectations has led to uncertainty in control strategies and concerns for the operational and cost impacts on coal-fired power generation with mercury controls.

However, an IGCC power plant has the potential of achieving very high mercury removal performance with established technology. IGCC plants have the potential of removing mercury from the syngas upstream of the gas turbine. Syngas volumes are much smaller at this point. Thus, mercury removal in an IGCC has the potential to be both less complex and less expensive. As a result, mercury removal in an IGCC power plant can be expected to be very high in removal effectiveness, low in cost, and reliable in design.

Parsons developed a conceptual design and cost estimate for applying a carbon bed adsorption system to estimate the cost of mercury control in an IGCC plant. The IGCC plant design was based on a reference design developed by Parsons. Input on the performance of carbon bed systems was obtained from Eastman Chemical Company, based on their substantial commercial operating experience with this technology. This conceptual design and cost estimate is specifically applicable to gasification systems using high-temperature slagging gasifiers and bituminous coal, which includes most of the coal gasification plants in the U.S. that are currently operating or are in various planning stages.

The cost format was based on the methodology used in the EPA Mercury Study Report to Congress, while the cost estimate (capital and operations and maintenance, or O&M) was based on Parsons' in-house data and experience. The purchased equipment costs were scaled from Parsons' in-house data for pressure vessels used in a syngas application. The total capital cost is \$3.34 per kilowatt.

O&M costs were based on factors for labor, material, and overhead. Carbon costs were by far the largest O&M cost factor, amounting to over 67 percent of the O&M costs. The total O&M is \$0.183/MWh (or mills/kWh). Based on a 15 percent capital recovery factor, the total cost per year is \$0.254/MWh or \$3,412 per pound of mercury.

The study evaluated the sensitivity of the costs on five key parameters including mercury concentration, capital costs, carbon costs, carbon replacement time, and increasing mercury capture.

The cost of removal of mercury by a carbon bed in an IGCC plant is lower than in a pulverized coal (PC) plant. The mercury is removed from the compressed syngas in an IGCC plant, which greatly reduces the acfm (actual cubic feet per minute) and thus the size of the equipment and the number of beds. The estimated cost of \$0.254 per MWh and \$3,412 per pound of mercury can be compared to estimates of costs of mercury removal from PC power plants. In the EPA Mercury Study Report to Congress, the cost for 90 percent mercury removal from a 975 MW utility boiler using carbon beds was reported at \$3.10 per MWh and \$37,800 per pound of mercury.

The costs for mercury removal in PC plants can be an order of magnitude higher than the removal costs in an IGCC plant. However, the additional capital cost increment to add 90 percent mercury removal to an IGCC plant is less than 0.3 percent and the increase in the cost of electricity is less than one percent.

## **2. INTRODUCTION**

The EPA has decided to regulate mercury emissions from coal burning utilities. A proposed regulation will be due no later than December 15, 2003, and promulgated the following year. Currently, no single technology has been proven that can uniformly control mercury from power plant flue gas emissions in a cost-effective manner, while consistently achieving mercury removal levels of 90 percent. The effectiveness of existing flue gas emission controls in removing mercury can vary considerably from plant to plant, or even from boiler to boiler. With today's technologies, mercury removal can range from essentially no control to as high as 90 percent. This variability in control costs and performance expectations has led to uncertainty in control strategies and concerns for the operational and cost impacts on coal-fired power generation with mercury controls.

However, an integrated gasification combined cycle (IGCC) power plant has the potential of achieving very high mercury removal performance with established technology. IGCC plants have the potential of removing mercury from the syngas upstream of the gas turbine. Syngas volumes are much smaller at this point. Thus, mercury removal in an IGCC has the potential to be both less complex and less expensive. As a result, mercury removal in an IGCC power plant can be expected to be very high in removal effectiveness, low in cost, and reliable in design.

The objective of this study was to prepare a conceptual design and a cost estimate of a carbon bed adsorption system for application to an IGCC plant configuration typical of coal-based gasification plants that would be subject to the proposed mercury regulations. This study showed a cost advantage of mercury removal in an IGCC plant, based on the following two attributes:

- There is an existing operating experience base on which the design and cost estimate can be reliably based; thus, the application to future plants can be made with low uncertainty.
- The mercury removal step in an IGCC plant can be located at a point in the process where the volumetric flow rate is much smaller than would be for post-combustion applications; thus, smaller equipment can be used.

Parsons developed a conceptual design and cost estimate for applying a carbon bed adsorption system to estimate the cost of mercury control in an IGCC plant. The IGCC plant was based on a reference IGCC plant developed by Parsons with input from Tampa Electric Company and Texaco Power.<sup>1</sup> The basis of the reference plant is the clean coal technology (CCT) demonstration plant installed at Polk County, Florida. Input on the performance of carbon bed systems was obtained from the Eastman Chemical Company, which uses carbon beds at its syngas facility in Kingsport, Tennessee.<sup>2</sup>

---

<sup>1</sup> "Clean Coal Reference Plants: IGCC Texaco," Parsons, December 2001.

<sup>2</sup> Telephone communication with Dave Denton, Eastman Chemical Company.

### **3. BACKGROUND**

#### **3.1 REGULATORY INITIATIVES**

The EPA has announced that it will regulate emissions of mercury and other air toxics from coal- and oil-fired electric utility steam generating units (power plants). Mercury has been identified by the EPA as the toxic substance of greatest concern among all the air toxics emitted from power plants. Coal-fired power plants are the nation's largest source of mercury air emissions in the United States – about 43 tons of mercury each year.

The EPA must propose regulations to control mercury emissions from coal- and oil-fired power plants by December 15, 2003 and issue final regulations by December 15, 2004. Under this timetable, regulations would require utility compliance by December 2007 because the Clean Air Act requires sources to install maximum achievable control technologies (MACT) three years after regulations are promulgated.

#### **3.2 MERCURY REMOVAL FOR CONVENTIONAL COAL-FIRED PLANTS**

The ability to achieve 90 percent removal with established reliability and reasonable cost has not yet been established for coal-fired plants and continues in development and evaluation. As a result, there are concerns and uncertainties as to how effectively mercury removal can be achieved and the potential cost impacts on power generation. For conventional coal-fired power plants, the mercury removal step will likely be applied post-combustion, where the full quantity of combustion oxygen and the accompanying diluent nitrogen from the air supply increases the volume of the gas stream.

In the EPA Mercury Study Report to Congress, the costs for 90 percent mercury removal from a 975 MW utility boiler were reported for three technologies including carbon beds, activated carbon injection, and activated carbon injection with spray cooling.<sup>3</sup> The costs ranged from \$1.43 per MWh and \$17,400 per pound of mercury for activated carbon injection with spray cooling to \$3.10 per MWh and \$37,800 per pound of mercury for carbon beds.

EPRI has recently summarized the costs of mercury removal in power plants.<sup>4</sup> Their average baseline costs for various carbon injection systems at 90 percent mercury removal ranged from \$2.80 per MWh to \$3.30 per MWh.

As a frame of reference, the cost of electricity without a mercury removal process is typically about \$35/MWh. The "Market-Based Advanced Coal Power Systems – Final Report, May 1999," prepared by Parsons for the DOE<sup>5</sup>, used the same calculation methodology as this study and determined the cost of electricity for ten power plant systems (including IGCC, PC, and fluidized-bed coal, and natural gas combined cycle plants) to range from \$31 to \$39/MWh.

---

<sup>3</sup>"Mercury Study Report to Congress: Volume VIII, An Evaluation of Mercury Control Technologies and Costs," EPA-452/R-97-010, December 1997, page 3-6.

<sup>4</sup>Chang, R. and Offen, G., "Mercury Control Options," Modern Power Systems, November 2001.

<sup>5</sup> [http://www.fe.doe.gov/coal\\_power/special\\_rpts/market\\_systems/market\\_sys.shtml](http://www.fe.doe.gov/coal_power/special_rpts/market_systems/market_sys.shtml)

Thus, the above estimated cost of mercury removal would represent an increase of as much as 5 to 10 percent in the cost of electricity.

### **3.3 MERCURY REMOVAL EXPERIENCE IN GASIFICATION**

#### **3.3.1 Activated Carbon**

One of the principal suppliers and developers of activated carbon adsorbents for mercury removal, as well as for other gas components, is Calgon Carbon Corporation in Pittsburgh, Pennsylvania. The Calgon Type-HGR carbon has been used for low-pressure drop adsorption of mercury from natural gas since the early 1970s. There are many other activated carbon suppliers worldwide. The carbon is impregnated with sulfur at a concentration of about 10 to 15 wt%, and mercury reacts with sulfur as the gas goes through the sulfur-impregnated carbon bed to form mercuric sulfide (HgS). After the sulfur on the carbon is exhausted, the spent adsorbent is shipped to a hazardous chemicals disposal site. HgS is a very stable compound and its long-term storage presents no problems. The spent carbon can also be incinerated and the mercury recovered from the incinerator gas via cooling and condensation. In this case, a complex and expensive cooling/condensation method would be used, followed by trim gas phase carbon beds for residual mercury removal, and flue gas scrubbing for the resulting SO<sub>2</sub>.

The Eastman Chemical Company's chemicals from coal facility began operations in 1983 and was the first use of a Texaco quench gasifier to provide feed gas for the production of acetyl chemicals. This facility also employed carbon beds to remove mercury from the syngas. The syngas production area produces raw gases, which are split into two process streams. About one-third of the raw gas is routed to the shift reactor. Both gas streams are cooled and then sent to individual carbon beds for mercury and other heavy metal removal. Each stream is then sent to a Rectisol sulfur recovery unit.

The purpose of the mercury removal is to protect the acetyl chemical product from any mercury contamination. Sulfur-impregnated activated carbon is used as the adsorbent in the packed beds operated at 86°F and 900 psi. A 90 to 95 percent mercury removal has been reported with a bed life of 18 to 24 months. Eastman has yet to experience any mercury contamination in its product.<sup>2</sup>

Higher levels of mercury removal from synthesis gas have not yet been verified. However, there is commercial experience in nearly total mercury removal from natural gas. Calgon has supplied activated carbon to a Texas pipeline company that achieves well over 99.99 percent mercury removal from high-pressure natural gas. In that case, the mercury in the inlet gas is about 50 µg/Nm<sup>3</sup> (approximately 70 ppbw), and the mercury in the outlet gas is 0.001 µg/Nm<sup>3</sup> (below detectable limits). The inlet mercury concentration of this natural gas case is similar to what one would expect in the synthesis gas from gasification of bituminous coal. There is reason to expect that carbon beds could also remove mercury from synthesis gas to below detectable levels. However, if carbon beds are designed for mercury removal, attention also has to be paid to any other trace components that can be adsorbed by carbon. The mercury-carrying capacity of activated carbon can be significantly compromised by the presence of other trace compounds.

### 3.4 VARIABILITY OF MERCURY CONTENT IN COAL

In evaluating the design and cost of a mercury removal system, it is important to understand the applicability of the estimate to a variety of gasification feedstock materials and to make sure that the basis for the estimate can be considered to be representative. Table 1 shows a summary of test results of the mercury content of various coals.<sup>6</sup> Data on the average mercury content of petroleum coke and tires are also included in this table. The data show a wide variety of mercury content as measured, but the averages are within a range of  $\pm 50$  percent of the overall average. They are also within the designed capabilities of the carbon bed systems estimated in this study as shown by the sensitivity study. The mercury content of the coal is also not an important factor as explained by the limited influence of the mercury content of the coal (and thus the syngas stream) on the lifetime of the carbon bed. While the mercury content of coals can vary greatly, 100 ppbw is typical of the mercury content of high-sulfur bituminous coal, and is close to the overall average. This level of mercury content is also consistent with the measured value at the Polk County IGCC plant on which the reference plant design was based. With the exception of some of the waste coals analyzed, the average mercury content of the categories lies within the range of the design, cost, and sensitivity studies of this assessment.

**Table 1**  
**Mercury Content of Coals**

Fuel Type	Number of Analyses	Average Mercury Content (ppbw, dry)	Range (ppbw, dry)
Anthracite	65	113	60 – 230
Bituminous coal	27,355	137	1 – 1,300
Bituminous coal, high S	512	99	10 – 557
Bituminous coal, low S	563	89	10 – 912
Lignite	1,047	106	20 – 750
Petcoke	1,171	50	0.9 – 500
Subbituminous coal	8,614	71	8 – 900
Tires	149	56	10 – 328
Waste anthracite	426	190	40 – 540
Waste bituminous	572	464	33 – 1,180
Waste subbituminous	53	119	65 – 347
<b>Overall</b>	<b>40,527</b>	<b>107</b>	<b>0.9 – 1,300</b>

<sup>6</sup> <http://www.epa.gov/ttn/atw/combust/utilltox/utoxpg.html>

## **4. DESIGN CONSIDERATIONS**

The syngas flow rate, composition, and properties were taken from the IGCC plant design, based on the Tampa Electric IGCC Demonstration Project, which utilizes an entrained-flow, oxygen-blown Texaco gasification process.<sup>1</sup> Figure 1 is a block flow diagram of the plant. Table 2 shows the detailed compositions at each state point. The plant configuration is based on the radiant cooler gasifier mode. The power generation technology is based on selection of a gas turbine derived from the General Electric 7FA machine. The plant is configured with one gasifier including processes to progressively cool and clean the gas, making it suitable for combustion in the gas turbines. The resulting plant produces a net output of 250 MWe at an efficiency of 37.6 percent on an HHV basis. Performance is based on the properties of Pittsburgh No. 8 coal.

The raw synthesis gas exiting the radiant syngas cooler is cooled in the series of heat exchangers before entering the fuel gas scrubber. The cooled syngas at 450°F then enters the scrubber for particulate removal. The quench scrubber washes the syngas in a counter-current flow in two packed beds. After leaving the scrubber at a temperature of about 290°F, the gas is suitable for feeding to the COS hydrolysis reactor. The quench scrubber removes essentially all traces of entrained particles, principally unconverted carbon, slag, and metals. Following the syngas scrubber, the gas is reheated to 410°F and fed to the COS hydrolysis reactor. The COS is hydrolyzed with steam in the gas over a catalyst bed to H<sub>2</sub>S, which is more easily removed by the acid gas removal (AGR) solvent. Before the raw fuel gas can be treated in the sulfur removal process, it must be cooled to 103°F. During this cooling, most of the water vapor condenses. The promoted monodiethanolamine (MDEA) process for AGR was chosen because of its high selectivity toward H<sub>2</sub>S and because of the low partial pressure of H<sub>2</sub>S in the fuel gas. The AGR process utilizes an MDEA sorbent and several design features to effectively remove and recover H<sub>2</sub>S from the fuel gas stream. The MDEA solution is relatively expensive, and measures are taken to conserve the solution during operations. As the presence of CO causes amine degradation in the form of heat stable salts, an amine reclaimer is included in the process. Also, additional water wash trays are included in the absorber tower to prevent excessive solvent loss due to vaporization. Fuel gas enters the absorber tower at 103°F and 378 psia. Approximately 99 percent of the H<sub>2</sub>S is removed from the fuel gas stream. The resulting clean fuel gas stream exits the absorber and is heated in a regenerative heater to 310°F. H<sub>2</sub>S is regenerated and sent in a concentrated stream to the Claus plant.

Figure 1  
Modified Block Flow Diagram  
Texaco Gasifier-Based IGCC Reference Plant

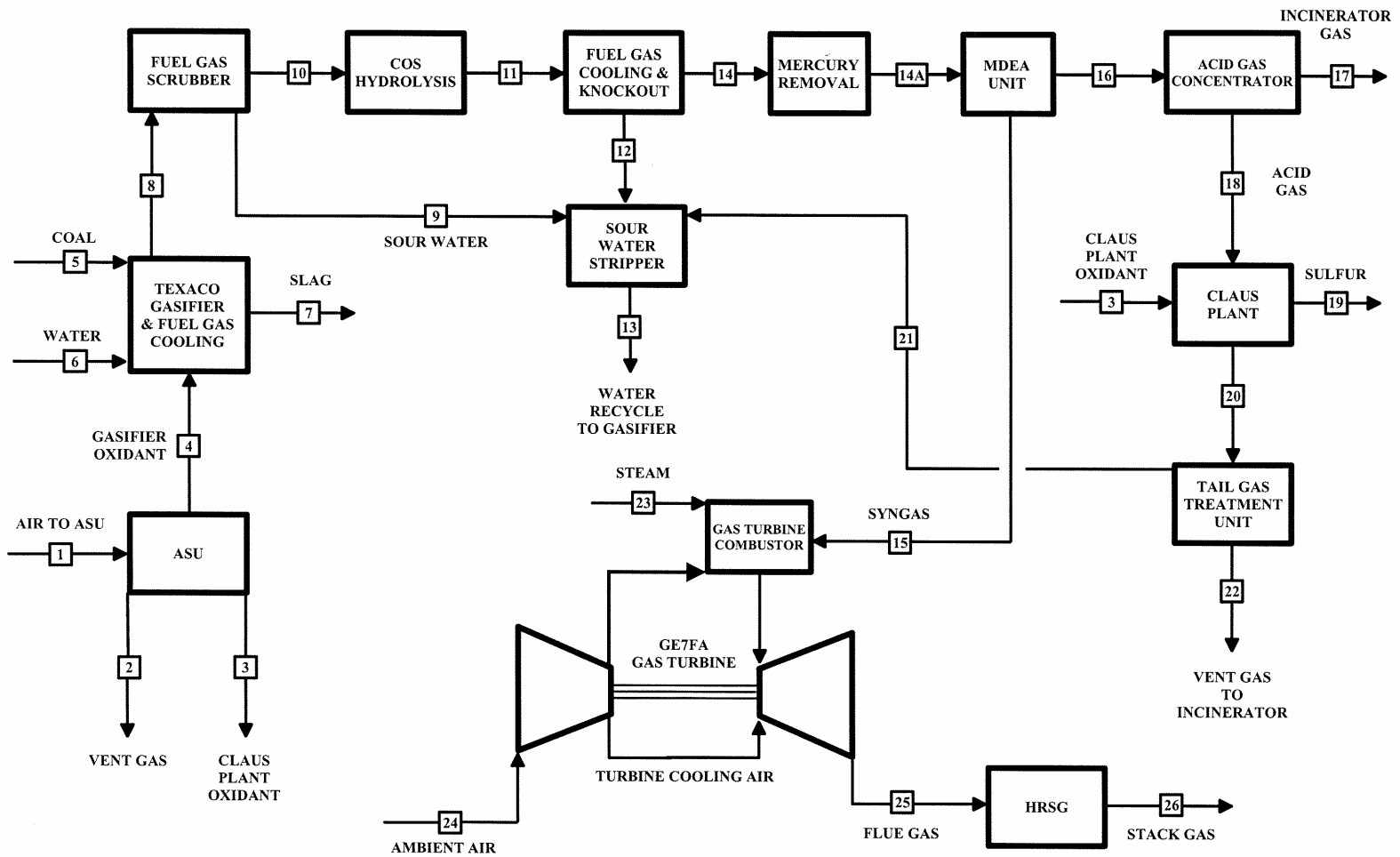

**Table 2**  
**Texaco IGCC Plant – Detailed Composition (page 1 of 3)**

Stream Number	1	2	3	4	5	6	7	8	9
<b>Vapor - Liquid</b>									
<b>Mole Fraction</b>									
Ar	0.0094	0.0029	0.0360	0.0360	0.0000	0.0000	0.0000	0.0094	0.0012
CH <sub>4</sub>	0.0000	0.0000	0.0000	0.0000	0.0000	0.0000	0.0000	0.0006	0.0001
CO	0.0000	0.0000	0.0000	0.0000	0.0000	0.0000	0.0000	0.4160	0.0074
CO <sub>2</sub>	0.0003	0.0004	0.0000	0.0000	0.0000	0.0000	0.0000	0.1078	0.0302
H <sub>2</sub>	0.0000	0.0000	0.0000	0.0000	0.0000	0.0000	0.0000	0.3002	0.0067
H <sub>2</sub> O	0.0104	0.0131	0.0000	0.0000	0.0000	1.0000	0.0000	0.1488	0.7782
N <sub>2</sub>	0.7722	0.9645	0.0140	0.0140	0.0000	0.0000	0.0000	0.0070	0.0002
O <sub>2</sub>	0.2077	0.0191	0.9500	0.9500	0.0000	0.0000	0.0000	0.0000	0.0000
<b>COS (ppm)</b>	0	0	0	0	0	0	0	763	734
<b>H<sub>2</sub>S (ppm)</b>	0	0	0	0	0	0	0	7,764	20,512
<b>NH<sub>3</sub> (ppm)</b>	0	0	0	0	0	0	0	1,570	154,789
<b>SO<sub>2</sub> (ppm)</b>	0	0	0	0	0	0	0	0	0
<b>Total V-L Flow (lbmol/h)</b>	28,975	23,105	89	5,779	0	4,778	0	22,081	148
<b>Total V-L Flow (lb/h)</b>	836,054	646,943	2,870	186,247	0	86,071	0	454,926	2,809
<b>Solids (lb/h)</b>									
<b>Coal</b>	0	0	0	0	209,208	0	0	0	0
<b>Slag</b>	0	0	0	0	0	0	26,322	266	266
<b>Sulfur</b>	0	0	0	0	0	0	0	0	0
<b>Temperature (°F)</b>	59	60	90	227	59	59	200	450	314
<b>Pressure (psia)</b>	14.7	20.0	30.0	650.0	14.7	14.7	15.0	430.0	430.0

**Table 2**  
**Texaco IGCC Plant – Detailed Composition (page 2 of 3)**

Stream Number	10	11	12	13	14	15	16	17	18
<b>Vapor - Liquid</b>									
<b>Mole Fraction</b>									
Ar	0.0095	0.0095	0.0000	0.0000	0.0110	0.0116	0.0000	0.0000	0.0000
CH <sub>4</sub>	0.0006	0.0006	0.0000	0.0000	0.0007	0.0008	0.0000	0.0000	0.0000
CO	0.4188	0.4188	0.0000	0.0000	0.4880	0.5127	0.0040	0.0068	0.0000
CO <sub>2</sub>	0.1083	0.1091	0.0001	0.0000	0.1271	0.0935	0.7906	0.9883	0.4994
H <sub>2</sub>	0.3022	0.3022	0.0000	0.0000	0.3521	0.3699	0.0029	0.0049	0.0000
H <sub>2</sub> O	0.1446	0.1438	0.9960	1.0000	0.0027	0.0029	0.0000	0.0000	0.0000
N <sub>2</sub>	0.0070	0.0070	0.0000	0.0000	0.0082	0.0086	0.0000	0.0000	0.0000
O <sub>2</sub>	0.0000	0.0000	0.0000	0.0000	0.0000	0.0000	0.0000	0.0000	0.0000
COS (ppm)	763	8	0	0	9	9	0	0	0
H <sub>2</sub> S (ppm)	7,678	8,433	114	0	9,807	52	202,395	3	500,565
NH <sub>3</sub> (ppm)	538	538	3,785	0	324	0	0	0	0
SO <sub>2</sub> (ppm)	0	0	0	0	0	0	0	0	0
Total V-L Flow (lbmol/h)	21,933	21,933	3,115	4,778	18,824	17,867	908	541	367
Total V-L Flow (lb/h)	452,117	452,117	56,122	86,071	396,099	357,167	37,949	23,623	14,326
<b>Solids (lb/h)</b>									
Coal	0	0	0	0	0	0	0	0	0
Slag	0	0	0	0	0	0	0	0	0
Sulfur	0	0	0	0	0	0	0	0	0
Temperature (°F)	410	411	111	59	103	310	120	123	127
Pressure (psia)	415.0	402.0	378.0	14.7	378.0	362.5	35.0	30.0	30.0

**Table 2**  
**Texaco IGCC Plant – Detailed Composition (page 3 of 3)**

Stream Number	19	20	21	22	23	24	25	26
<b>Vapor - Liquid</b>								
<b>Mole Fraction</b>								
Ar	0.0000	0.0066	0.0000	0.0109	0.0000	0.0094	0.0093	0.0093
CH <sub>4</sub>	0.0000	0.0000	0.0000	0.0000	0.0000	0.0000	0.0000	0.0000
CO	0.0000	0.1045	0.0000	0.0139	0.0000	0.0000	0.0000	0.0000
CO <sub>2</sub>	0.0000	0.3290	0.0000	0.5957	0.0000	0.0003	0.0803	0.0803
H <sub>2</sub>	0.0000	0.0555	0.0000	0.2184	0.0000	0.0000	0.0000	0.0000
H <sub>2</sub> O	0.0000	0.4556	1.0000	0.1009	1.0000	0.0104	0.1608	0.1608
N <sub>2</sub>	0.0000	0.0364	0.0000	0.0600	0.0000	0.7722	0.6370	0.6370
O <sub>2</sub>	0.0000	0.0000	0.0000	0.0000	0.0000	0.2077	0.1126	0.1126
COS (ppm)	0	521	0	95	0	0	0	0
H <sub>2</sub> S (ppm)	0	5,505	10	103	0	0	0	0
NH <sub>3</sub> (ppm)	0	0	0	0	0	0	0	0
SO <sub>2</sub> (ppm)	0	6,221	0	0	0	0	8	8
Total V-L Flow (lbmol/h)	0	511	159	310	13,937	111,584	135,502	135,502
Total V-L Flow (lb/h)	0	14,119	2,856	9,616	251,080	3,219,670	3,827,920	3,827,920
<b>Solids (lb/h)</b>								
Coal	0	0	0	0	0	0	0	0
Slag	0	0	0	0	0	0	0	0
Sulfur	6,001	5	0	0	0	0	0	0
Temperature (°F)	347	280	120	123	500	59	1,131	280
Pressure (psia)	23.6	23.6	16.5	14.9	350.0	14.7	14.8	14.7

The operation of the combined cycle unit in conjunction with oxygen-blown IGCC technology is projected to result in very low levels of emissions of NO<sub>x</sub>, SO<sub>2</sub>, and particulate (slag). A salable byproduct is produced in the form of elemental sulfur. The low level of SO<sub>2</sub> in the plant emissions is achieved by capture of the sulfur in the gas by the amine-based MDEA acid gas removal (AGR) process.

NO<sub>x</sub> emissions are limited to approximately 15 ppm by the use of steam injection. The ammonia is removed with process condensate prior to the low-temperature AGR process. This helps lower NO<sub>x</sub> levels as well. The techniques of selective catalytic reduction (SCR) or selective non-catalytic reduction (SNCR) can reduce emissions further, but were not necessary. Particulate discharge to the atmosphere is limited to low values by the gas-washing effect of the syngas scrubber and the AGR absorber.

#### **4.1 CARBON BED LOCATION**

Calgon Carbon has product bulletins providing process design guidance information<sup>7</sup> that is helpful in the selection of the carbon bed location. The information was available for elevated pressures consistent with the IGCC reference plant design. Based on their curves for pressure drop through beds of either their granular 4x10 U.S. mesh carbon or their 4 mm diameter pellets, estimates of the pressure drop and sizing of the beds could be made. The pressure drop through the bed of pellets selected as the basis for this design and estimate is about 20 percent less than with the granular carbon.

The Calgon information also addressed the temperature effects on the effectiveness of mercury removal. At temperatures of around 100°F and lower, the concentration of mercury can be reduced readily to levels of 0.01 µg/Nm<sup>3</sup> (less than 1 ppbw) and substantially lower. At temperatures of 160°F and above, removal to below 0.01 µg/Nm<sup>3</sup> cannot be consistently achieved. The mercury removal rate and removal limit are relatively insensitive to pressure in the applicable range and are adversely affected by moisture level and the presence of water adsorbed on the carbon.

As seen in Figure 1, there are numerous syngas sites from which mercury can be removed, but the Calgon removal guidelines tend to narrow the choices.

Stream 8 contains most of the contaminants from the gasified coal. However, attempting to remove the mercury from this stream would entail removing residual particulate matter from the syngas. Also, the 450°F temperature is significantly higher than the optimum operating temperature for carbon. Stream 10, located upstream of the COS hydrolysis unit, is at a temperature of 410°F and a pressure of 415 psia. Again, this stream is at high temperature for the carbon bed operation. Stream 15 is a clean stream following the AGR process; locating the mercury removal process there would subject the AGR process to mercury and other heavy metal contamination. Removing the mercury and other contaminants before the sulfur recovery unit should enhance the performance of the unit and increase the life of the solvent.

---

<sup>7</sup> Calgon Carbon Corporation Product Bulletin AB-742-06/94

Several of the more likely choices for locating the carbon bed adsorption system are summarized in Table 3. This table shows that the volumetric flow of treated gas is substantially lower as a low-temperature, high-pressure syngas stream prior to combustion and expansion of the syngas. This represents a significant advantage in the sizing and cost of equipment and the amount of carbon needed in the treatment system.

**Table 3**  
**Volumetric Flow Comparison**

Stream Number	14	15	25	26
Location	Syngas cooled, before sulfur removal	Syngas cooled, after sulfur removal	Flue gas, before HRSG	Stack gas
Flow Rate: lbmol/h 10 <sup>3</sup> lb/h	18,824 396	17,867 357	135,502 3,828	135,502 3,828
Temperature, °F	103	310	1131	280
Pressure, psia	378	362.5	14.8	14.7
Volumetric Flow Ratio*	1.00	1.35	520	244

\* Ratio of volumetric flow rate compared to the selected location after the syngas cooler and prior to the sulfur removal system. Volumetric flow rates adjusted for temperature and pressure.

Locating the carbon beds downstream of the syngas coolers substantially reduces the level of moisture in the syngas as shown in comparing Streams 11 and 14 in Table 2, where the moisture content is reduced from 0.1438 mole fraction to 0.0027.

Accordingly, the packed carbon bed vessels were located upstream of the AGR process in Stream 14 at a temperature of 103°F and a pressure of 378 psia. Figure 1 has the location of the mercury removal process identified. A separate stream table, Table 4, shows the relative change in the properties and composition of Streams 14 and 14-A as a result of installing the mercury removal vessel. The stream pressure drops 10 psi and the mercury concentration drops from 52 ppbw to 5 ppbw.

**Table 4**  
**Effect of Mercury Removal on Stream Properties**

Stream Number	14 Before Hg Removal	14-A After Hg Removal
	Mole Fraction	Mole Fraction
Ar	0.0110	0.0110
CH <sub>4</sub>	0.0007	0.0007
CO	0.4880	0.4880
CO <sub>2</sub>	0.1271	0.1271
H <sub>2</sub>	0.3521	0.3521
H <sub>2</sub> O	0.0027	0.0027
N <sub>2</sub>	0.0082	0.0082
O <sub>2</sub>	0.0000	0.0000
COS (ppm)	9	9
H <sub>2</sub> S (ppm)	9,807	9,807
NH <sub>3</sub> (ppm)	324	324
SO <sub>2</sub> (ppm)	0	0
<b>Mercury (ppbw)</b>	<b>52</b>	<b>5</b>
Total V-L Flow (lbmol/h)	18,824	18,824
Total V-L Flow (lb/h)	396,099	396,099
Temperature (°F)	103	103
<b>Pressure (psia)</b>	<b>378.0</b>	<b>368.0</b>

Eastman Chemical also locates beds downstream of the gas cooling and ahead of the sulfur recovery unit. Our temperature of 103°F is close to the temperature of 86°F at which Eastman Chemical operates.<sup>2</sup>

## 4.2 MERCURY CONCENTRATION

The mercury input to the packed bed was based on mercury in the coal as measured at the Polk County IGCC plant of approximately 100 ppbw (0.0207 lb/hour<sup>8</sup>). This mercury content is consistent with the average levels reported for high-sulfur bituminous coal and the overall average as shown in the preceding Table 2. A concentration of 100 ppbw in the coal is equivalent to 52 ppbw in the syngas if all the mercury appears in the syngas. It is likely that

<sup>8</sup> NETL, Ohio State Meeting-GJS-07/10/01.

some mercury may be removed in the fuel gas scrubber as well as captured in the slag before it reaches the bed. At the Polk County plant, approximately 40 percent of the mercury in the coal was unaccounted for when measuring mercury emissions in the stack. It is reasonable to expect that some portion of this difference can be attributed to collection in the slag and the scrubber effluent. The performance estimate in this study is total mercury capture: that is, it assumes no mercury reduction upstream of the carbon beds.

### **4.3 PROCESS PARAMETERS**

An empty vessel basis gas residence time of approximately 20 seconds was used based on Eastman Chemical's experience.<sup>2</sup> Allowable gas velocities are limited by considerations of particle entrainment, bed agitation, and pressure drop. One-foot-per-second superficial velocity is in the middle of the range normally encountered<sup>8</sup> and was selected for this application. The density of 30 lb/ft<sup>3</sup> was based on the Calgon Carbon Corporation HGR-P sulfur-impregnated pelleted activated carbon.<sup>9</sup>

These parameters determined the amount of carbon needed, the size of the vessels, and the space velocity (the ratio of volumetric flow rate of gas to the volume of catalyst: 4,000 hour<sup>-1</sup> based on standard cubic feet or 200 hour<sup>-1</sup> based on actual cubic feet. While a single vessel of 10½-foot diameter was feasible, it was decided to use two smaller diameter vessels of 7½-foot diameter to add flexibility to the plant operations. The small number of vessels and the small size can be attributed to the reduced volumetric flow for the cooled syngas treated prior to the AGR system and the gas turbine combustion as noted in the earlier table.

The total bed pressure drop of about 10 psia was converted into a power cost penalty and included in the O&M cost estimate. In the sensitivities study, the addition of a second bed in series to achieve much higher mercury removal percentages added additional pressure drop and power penalties.

### **4.4 MERCURY REMOVAL**

Packed beds of sulfur-impregnated carbon have been applied to hydrogen streams of chlor-alkali plants and typically remove about 90 percent of the mercury content of the stream.<sup>10</sup> Eastman Chemical also uses sulfur-impregnated carbon in its bed and has experienced removals of 90 to 95 percent.<sup>2</sup> Carbon removals of greater than 99 percent can be achieved by the use of dual beds, i.e., two beds in series.

This study assumes that the use of sulfur-impregnated carbon in a carbon bed achieves 90 percent reduction of mercury emissions. Use of the pelletized form of the carbon was assumed. A cost sensitivity of increasing the removal to 99+ percent by adding a second bed to

---

<sup>9</sup> <http://www.calgoncarbon.com/bulletins/HGR-P.htm>

<sup>10</sup> "Mercury Study Report to Congress: Volume VIII, An Evaluation of Mercury Control Technologies and Costs," EPA-452/R-97-010, December 1997, page 2-24.

each train is also presented. This includes the effect of additional pressure drop and power penalty due to the addition of the second bed.

#### **4.5 CARBON REPLACEMENT TIME**

Eastman Chemical replaces its bed every 18 to 24 months.<sup>2</sup> However, it is not because of mercury loadings that the bed is replaced, but for other reasons including:

- A buildup in pressure drop.
- A buildup in water in the bed.
- A buildup of other contaminants.

For this study an 18-month carbon replacement cycle has been assumed. Under these assumptions, the mercury loading in the bed would build up to 0.4 weight percent. Mercury capacity of sulfur-impregnated carbon can be as high as 20 weight percent.<sup>11</sup> Even with the highest mercury content found in various coals as reported in Table 1 (1,300 ppbw), the loading after 18 months would be only 9.6 percent. The moisture content reduction by condensation in the fuel gas cooling and knockout section before the AGR also aids the carbon bed lifetime. Thus, under most conditions, mercury loading should not be a factor in carbon replacement time.

---

<sup>11</sup> [http://www.calgoncarbon.com/bulletins/TYPE\\_HGR.htm](http://www.calgoncarbon.com/bulletins/TYPE_HGR.htm)

## 5. DESIGN BASIS

Table 5 summarizes the design basis used for this study.

**Table 5**  
**Design Basis**  
**Mercury Removal by a Carbon Bed – Fixed-Bed Option**

Syngas, lb mol/h	18,824
Syngas, lb/h	396,099
Molecular weight	21.0
Temperature, °F	103
Pressure, psia	378
Mercury concentration, ppbw	52
Carbon field packed density, lb/ft <sup>3</sup>	30
Carbon loading, lb mercury/lb carbon	0.39%
Space velocity, h <sup>-1</sup>	4,000
Syngas, scf/h	6,757,816
Syngas, acf/h	300,729
Absorbent carbon, scf	1,689
Cycle time absorption, h	10,515
Superficial velocity, ft/sec	1.00
Number of vessels	2
Vessel ID, ft	7.3
Bed height, ft	20.2
Carbon life, cycles	1
Carbon replacement time, year	1.50
Carbon replacement rate, ton/year	16.9
Initial carbon charge, ton	25

## **6. COST ESTIMATE**

Table 6 presents estimated costs for applying this packed bed carbon adsorption system to an IGCC plant. The cost format was based on the methodology used in the EPA Mercury Study Report to Congress,<sup>12</sup> while the cost estimate (capital and O&M) was based on Parsons' in-house data and experience.

The purchased equipment costs were scaled from Parsons' in-house data for pressure vessels used in a syngas application. The installation cost, which includes foundations and piping, was estimated to be 50 percent of the purchased equipment costs. The total capital cost came to \$834,350 or \$3.34 per kilowatt. The ratio of equipment costs to total costs of a little more than two is consistent with the recent Reference Design.<sup>1</sup>

O&M costs were based on factors for labor, material, and overhead. Carbon costs were based on Calgon Carbon Corporation's list price for pelletized, sulfur-impregnated carbon of \$6.43/lb.<sup>13</sup> Carbon costs are by far the largest O&M cost factor, amounting to over 67 percent of the O&M costs.

Disposal costs of \$500/ton were estimated assuming hazardous waste disposal. The total O&M is \$320,683. Based on a 15 percent capital recovery factor, which is typical for a power plant, the total cost per year is \$445,836 or \$0.254/MWh (or mills/kWh). The cost of mercury reduction is \$3,412 per pound.

---

<sup>12</sup> "Mercury Study Report to Congress: Volume VIII, An Evaluation of Mercury Control Technologies and Costs," EPA-452/R-97-010, December 1997, Appendix B.

<sup>13</sup> Telephone communication with Calgon Carbon Corporation.

**Table 6**  
**Cost Estimate**  
**Mercury Removal by a Carbon Bed – Fixed-Bed Option**

<b>PLANT PARAMETER</b>	
Plant net capacity, MWe	250
Hg level before fixed bed, ppbw	52
Hg level after fixed bed, ppbw	5
Capacity factor, %	80
<b>CAPITAL COST (\$)</b>	
Purchased equipment (PE) <sup>1</sup>	\$407,000
Installation <sup>2</sup>	\$203,500
Indirects <sup>3</sup>	\$122,100
Contingency <sup>4</sup>	\$101,750
Total capital costs (TCC)	\$834,350
TCC, \$/kW	\$3.34
<b>OPERATING &amp; MAINTENANCE COST (\$/year)</b>	
Operating labor <sup>5</sup>	\$4,380
Supervision <sup>6</sup>	\$657
Maintenance labor <sup>7</sup>	\$2,409
Maintenance material <sup>8</sup>	\$8,344
Carbon <sup>9</sup>	\$217,203
Power <sup>10</sup>	\$36,792
Disposal <sup>11</sup>	\$8,445
Overhead <sup>12</sup>	\$9,080
Taxes, insurance, administration <sup>13</sup>	\$33,374
Total O&M	\$320,683
Capital recovery <sup>14</sup>	\$125,153
<b>Total, \$/year</b>	<b>\$445,836</b>
<b>Total, \$/MWh</b>	<b>\$0.254</b>
Mercury reduction, lb/year	131
Mercury, \$/lb	\$3,412
<i>Notes:</i>	
1	<i>Scaled from Parsons' in-house data</i>
2	<i>50 percent of PE costs</i>
3	<i>30 percent of PE costs</i>
4	<i>25 percent of PE costs</i>
5	<i>1 hour/shift @ \$20/h</i>
6	<i>15 percent of operating labor costs</i>
7	<i>0.5 hour/shift @ 10% wage rate premium over labor wage</i>
8	<i>1 percent of TCC</i>
9	<i>Based on Calgon Carbon Corporation list price of \$6.43/lb for sulfur-impregnated carbon, pelletized</i>
10	<i>Using a pressure drop of 10 psi and 35 mills per kWh</i>
11	<i>Based on hazardous waste disposal of \$500/ton</i>
12	<i>60 percent of labor and maintenance costs</i>
13	<i>4 percent of TCC</i>
14	<i>Capital recovery factor of 15%</i>

## 7. SENSITIVITIES

Table 7 shows the results of a sensitivity analysis to determine the impact of increased mercury concentration if one, for example, co-fired municipal solid waste (MSW) with coal. Co-firing 10 percent MSW would increase the mercury concentration in the syngas from 52 ppbw to 100 ppbw; co-firing 25 percent MSW would increase it to 150 ppbw.

The mercury concentration does not affect the size of the filter or the amount of carbon used. Since the mercury loadings, even at these increased levels, are well below the carbon capacity, they would not impact the carbon replacement rate. Thus, none of the capital and the O&M costs would be impacted. However, the cost per pound of mercury removed decreases because of the increased amount of mercury removed annually by the carbon bed.

**Table 7**  
**Sensitivity of Increased Mercury Concentration**

Mercury concentration in the syngas, ppbw	52	100	150
Mercury reduction, lb/year	131	250	375
Reduction costs, \$/lb	\$3,412	\$1,785	\$1,190

The sensitivity of the costs on four other key parameters including capital costs, carbon costs, carbon replacement time, and increasing mercury removal levels was evaluated. Increasing the mercury removal level from 90 to 99 percent was based on doubling the number of beds and having two beds in series. Table 8 shows the results of these sensitivity studies.

**Table 8**  
**Sensitivity of Key Parameters**

Capital costs factor	0.50	1.0	2.0
Capital Costs, \$/kW	1.67	3.34	6.67
Total cost, \$/MWh	0.205	0.254	0.353
Reduction costs, \$/lb	\$2,754	\$3,412	\$4,728
Carbon costs, \$/lb	\$3.22	\$6.43	\$12.86
Carbon cost factor	0.50	1.0	2.0
Total cost, \$/MWh	0.192	0.254	0.378
Reduction costs, \$/lb	\$2,581	\$3,412	\$5,075
Carbon replacement time, months	9	18	36
Carbon replacement factor	0.50	1.0	2.0
Total cost, \$/MWh	0.383	0.254	0.190
Reduction costs, \$/lb	\$5,139	\$3,412	\$2,549
Mercury removal, %		90	99+
Capital Costs, \$/kW		3.34	6.67
Total cost, \$/MWh		0.254	0.393
Reduction costs, \$/lb		\$3,412	\$4,791

Figure 2 shows a column chart for these same sensitivities.

**Figure 2**  
**Sensitivity of Key Parameters on Mercury Removal Costs**

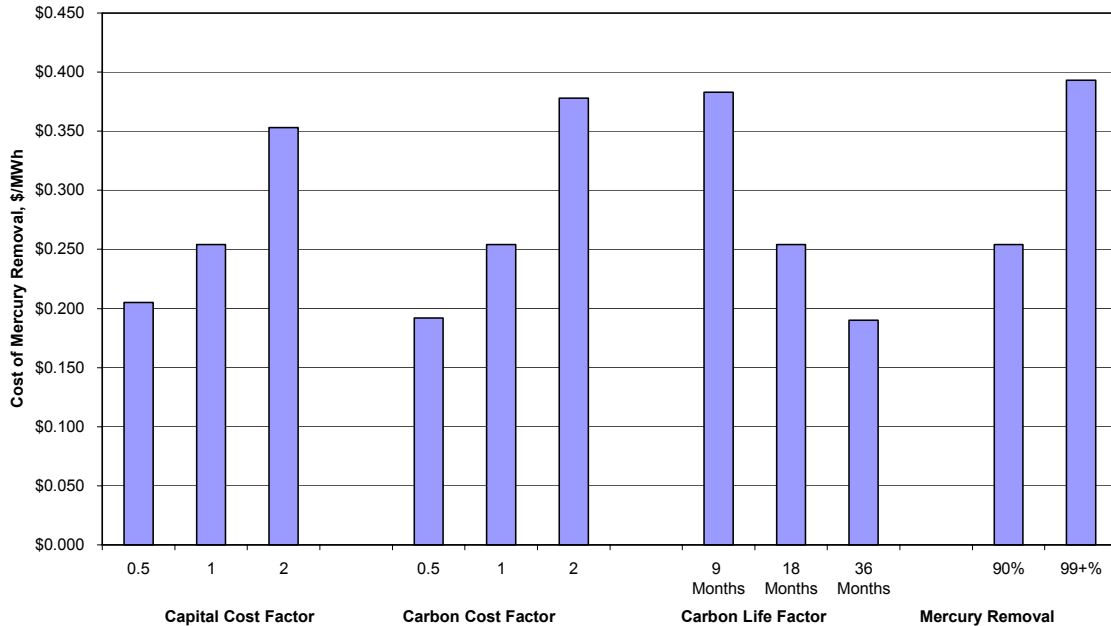

Doubling the capital costs increases the mercury reduction costs by a little more than one-third since these costs are only about one-third of the cost of mercury removal. Changes in the cost of carbon and the replacement time for carbon have a slightly larger impact on the cost of mercury removal than changes in the capital costs. The cost of sulfur-impregnated carbon is by far the largest cost item, amounting to over half of the total costs.

Increasing the mercury capture by using dual beds effectively doubles the capital costs but increases the cost of removal by only about one-half. The O&M costs increase by approximately 30 percent since the carbon replacement rate, which depends on the amount of contaminants removed, remains essentially the same.

## **8. APPLICABILITY OF ESTIMATE**

This particular study is based on mercury removal in an IGCC plant using a high-temperature slagging gasifier with bituminous coal and a low-temperature acid gas removal system. This is consistent with the low temperature constraints of the carbon beds for achieving very high levels of mercury removal. With this basis, the experience at Eastman Chemical in their coal gasification system is directly applicable and provides a level of confidence in the performance expectations. It is expected that this performance and cost estimate will also be reasonable when using low rank coals, such as sub-bituminous coal, as the mercury content is within the applicable range as shown in Table 1 and the gas composition would be expected to be somewhat similar to this case. Extensions of these results to low-temperature gasifiers, drastically different feedstocks, and flow schematics with higher temperature acid gas removal systems have not been addressed in this study and would likely need to be evaluated with experimental data. Of these, the strong interest in using “warm-gas” cleanup systems in the range of 350 to 700°F will be the most important process parameter to address in the future. For that case, a different adsorbent will need to be developed and demonstrated. The study case in this report represents the major portion of the existing and planned gasification plant base.

## **9. CONCLUSIONS**

The cost of mercury removal from an IGCC plant is reduced to very reasonable and acceptable levels by locating the carbon bed in the pressurized syngas stream. This stream is characterized as having a greatly reduced acfm (actual cubic feet per minute) of gas flow relative to that of stack gas by a factor of nearly 200 for the same size plant. Thus, the size of the equipment, the number of beds, and the consequent costs are much less than treating for mercury removal in the stack gas of either a PC plant or an IGCC plant. The estimated cost of \$0.254 per MWh and \$3,412 per pound of mercury from an IGCC plant can be compared to estimates of costs of mercury removal from PC power plants. For example, in the EPA Mercury Study Report to Congress, the cost for 90 percent mercury removal from a 975 MW utility boiler using carbon beds was \$3.10 per MWh and \$37,800 per pound of mercury.<sup>3</sup>

The capital cost estimate of \$3.34 per kW for removal from the IGCC plant represents less than 0.3 percent of the capital for the total IGCC plant. The small increase in the cost of electricity of \$0.254 per MWh due to adding the mercury removal system represents an increase in the overall cost of electricity from the plant of less than 1 percent. These measures of cost are substantially lower than that which might be expected of conventional coal power plant options.